

INSTALL VESA PLATE

1

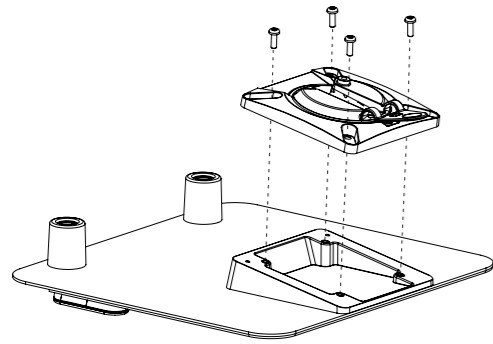

WARNING

Ensure the shorter screws (M4 x 10) provided with the VESA plate are used.

IMPORTANT

It is the responsibility of the installer to ensure all mounting screws are properly inserted into the mount. Under or over insertion may cause damage to the equipment or injury to personnel.

DO NOT exceed maximum recommended load.



INSTALL LAPTOP MOUNT TO ARM

2

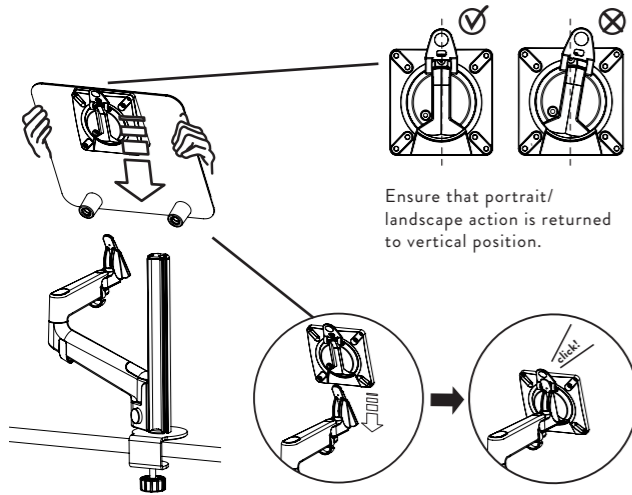

MOUNT LAPTOP

3

3A Pull out the retainers.

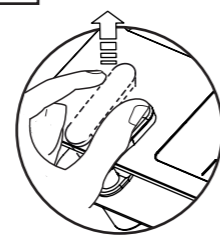

3B Push the laptop down into position on the Laptop Mount.

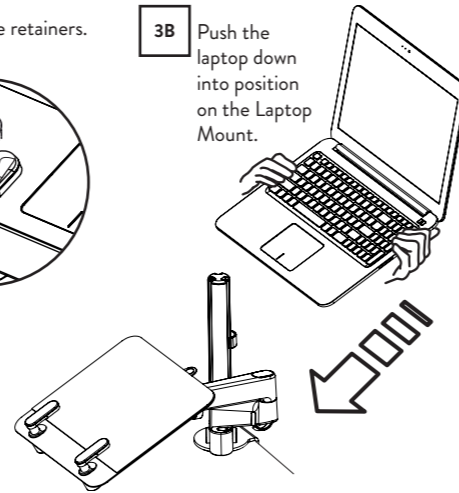

3C Push down the retainers to secure laptop.

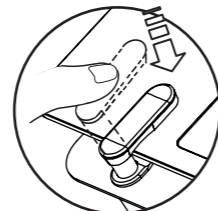

IMPORTANT
If mounting a laptop to a dynamic monitor arm, the spring tension may need to be adjusted to suit the mounted weight. Please refer to the instructions supplied with your chosen arm.

INSTALL LAPTOP CABLES INTO CABLE MANAGEMENT FEATURES

4

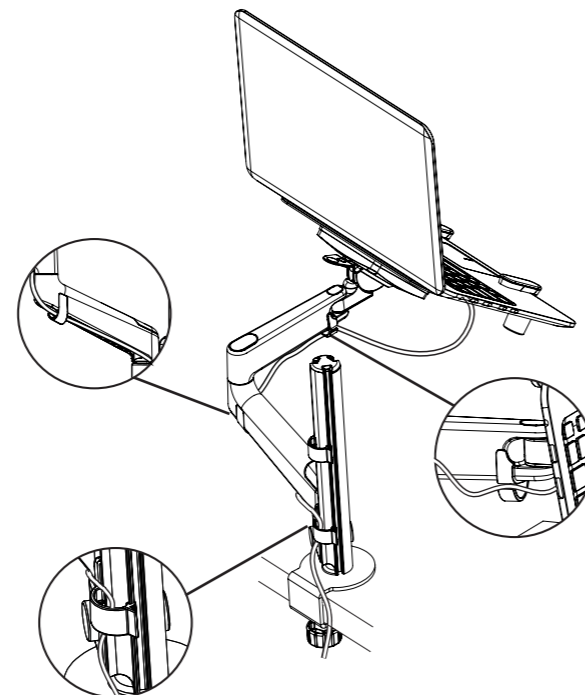

IMPORTANT

Ensure you leave enough free cable to avoid stretching or snagging at all positions of arm movement and laptop tilt.

USING YOUR LAPTOP MOUNT

5

Once it has been correctly set up, you will be able to easily position your laptop wherever you want it.

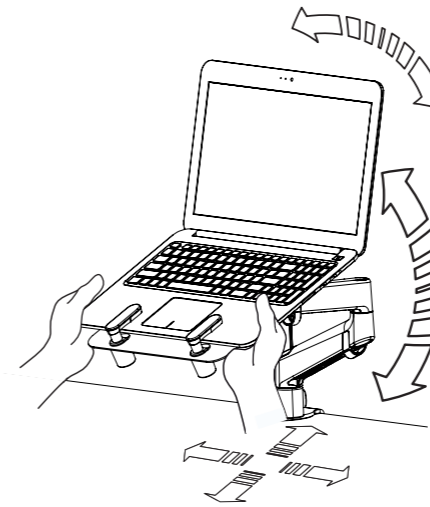

TIP

Please refer to instructions supplied with monitor arm on how to adjust height of arm.

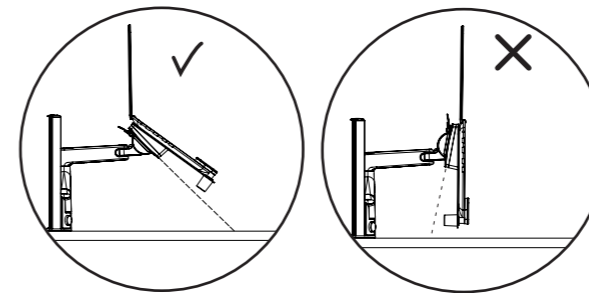

IMPORTANT

Ensure Laptop Mount does not go beyond vertical.

TO REMOVE LAPTOP FROM MOUNT

6

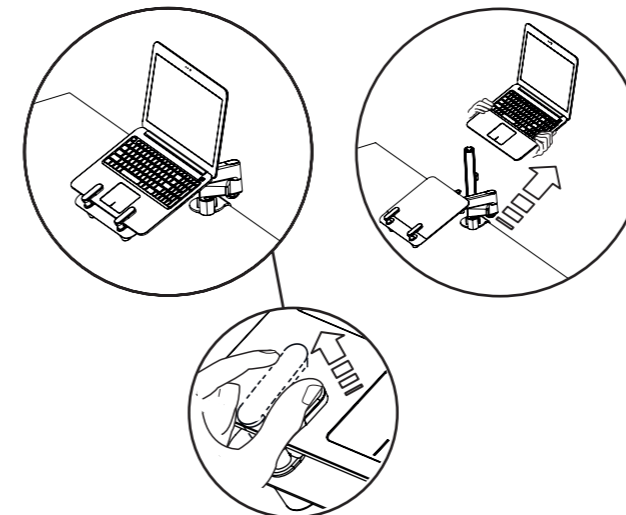

WARNING

Stored energy hazard when using a dynamic monitor arm. Arm mechanism is under tension and will spring up when load is removed. Failure to follow instructions could result in injury.

TO REMOVE LAPTOP MOUNT FROM ARM

7

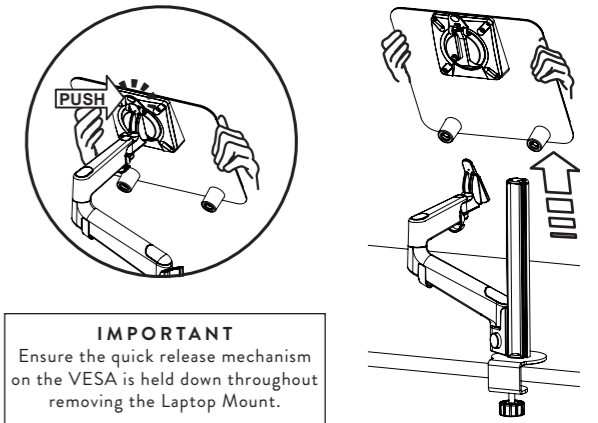

IMPORTANT

Ensure the quick release mechanism on the VESA is held down throughout removing the Laptop Mount.

WARNING

If using a dynamic monitor arm, raise arm to uppermost position before removing Laptop Mount, otherwise it may spring up when unloaded. Ensure the laptop is not on tray when removing.

NOTE

The Laptop Mount also supports dual screen working.

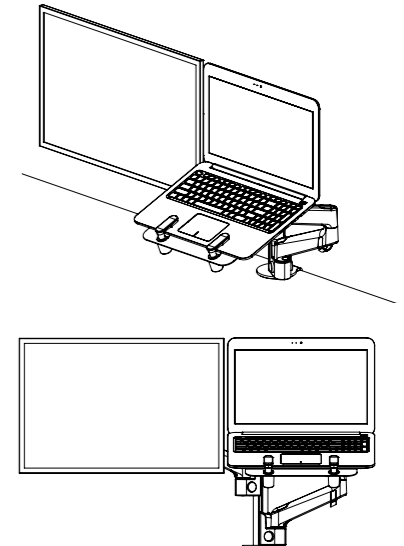

WARNING

- Ensure desk/work surface/wall/partition is suitable to take the weight of the products and devices.
- Do not use this product for any purpose other than that for which it was designed.
 - Supported weight must not exceed 2.8kg (6.2lb).
 - Hold the device tightly when making adjustments.
 - Care should be taken to avoid trapping fingers.
 - Do not dismantle or remodel this product.
- Do not mount the device before assembling the product.

MAINTENANCE AND INSPECTION

- Ensure all screws are tightened and occasionally adjust if needed.
- Clean with a damp cloth, NO solvent.

DISCLAIMER

As part of Colebrook Bosson Saunders ongoing product improvement programme, the design of products may change without prior notice and details may vary from those illustrated.

WARNUNG

- Sicherstellen, dass Schreibtisch/Arbeitsfläche/Wand/Trennwand das Gewicht von dem Produkt und dem montierten elektronischen Gerät tragen kann.
- Dieses Produkt nur für den Zweck verwenden, für den es konstruiert wurde.
 - Maximale Belastung darf 2,8kg (6,2lb) nicht überschreiten.
 - Das elektronische Gerät beim Einstellen gut festhalten.
 - Vorsicht: Nicht die Finger einklemmen.
- Das Produkt nicht auseinander nehmen oder umbauen.
- Das elektronische Gerät erst dann montieren, wenn das Produkt installiert ist.

WARTUNG UND INSPEKTION

- Sicherstellen, dass alle Schrauben festgezogen sind und, falls erforderlich, gelegentlich nachstellen.
- Mit einem feuchten Tuch säubern, KEINE Lösemittel.

AVERTISSEMENT ET MISE EN GARDE

- Assurez-vous que le bureau / la surface de travail / le mur / la cloison sont adaptés pour supporter le poids des produits et des appareils.
- Ce produit ne doit pas servir à d'autres fins que celle prévue.
- Le poids pris en charge ne doit pas dépasser 2,8 kg (6,2 lb).
- Tenez fermement l'appareil lorsque vous effectuez des réglages.
 - Faire attention à ne pas se coincer les doigts.
 - Ne démontez pas et ne remodelez pas ce produit.
- Ne montez pas l'appareil avant d'assembler le produit.

ENTRETIEN ET INSPECTION

- S'assurer que toutes les vis sont bien serrées et les resserrer au besoin.
- Nettoyer à l'aide d'un chiffon humide. PAS DE solvants.

ADVERTENCIA

- Asegurarse de que el escritorio/la superficie de trabajo/la pared/el tabique sea adecuado para soportar el peso de los productos y el dispositivo electrónico.
- No usar este producto para otro propósito que no sea aquel para el cual fue diseñado.
 - El peso soportado no debe exceder 2,8kg (6,2lb).
- Sujetar el dispositivo firmemente cuando se realicen ajustes.
 - Tomar precauciones para evitar pillarse los dedos.
 - No desarmar o remodelar el producto.
- No instalar el dispositivo electrónico antes de instalar el producto.

MANTENIMIENTO E INSPECCIÓN

- Asegurarse de que todos los tornillos estén apretados y ajustarlos de nuevo si fuera necesario.
- Limpiar con un paño húmedo, no utilizar solventes.

注意

- デスク / 作業台 / 壁 / 仕切りなどが、アームとモニターの重さに耐えられる事を確認して下さい。
- 本来の目的以外の目的で本製品を使わないで下さい。
- 各アームが支える重さは2.8kgを超えないようにして下さい。
- モニター角度調整中はモニターをしっかりと持って下さい。
- 指を挟まないように注意して下さい。
- 本製品を分解したり、組み立て直したりしないで下さい。
- アームを組み立てる前にモニターを設置しないで下さい。
- 壁に取り付けるためのねじは付属していません。
- 本製品取付部に凹みのあるモニターには、スペーサー、又は75mmのVESAプレートが必要な場合があります。

メンテナンスと点検

- すべてのネジが締まっていることを確認し、必要に応じて調整して下さい。固く絞った布で水拭きして下さい。

注意

- 请确保所有桌面/工作表面/隔板适合承受手臂和荧光屏的重量
- 切勿利用这产品在设计功能范围之外
- 每手臂承受重量不得大于2.8公斤(6.2磅)
- 当调整时, 请紧固定光屏
- 为了避免手指夹伤, 请谨慎
- 切勿拆或更改手臂
- 手臂还没完成组合之前, 切勿安装荧光屏
- 安装墙置托架的螺栓没提供
- 因某些荧光屏有凹面, 需要垫片或者75毫米VESA片

维修和检查

- 请确保所有螺栓必须紧固, 如需要, 请随时调整。请使用湿布清洁, 切勿使用溶剂

PATENTS

Colebrook Bosson Saunders hold a number of patents and other intellectual property rights covering our products and processes. You can find patent information on our website at: www.colebrookbossonsaunders.com/patents

COMPONENT LIST

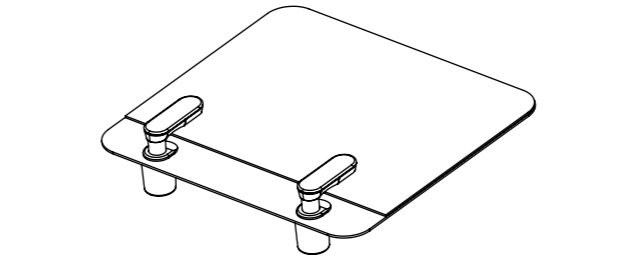

Lima Laptop Mount x 1

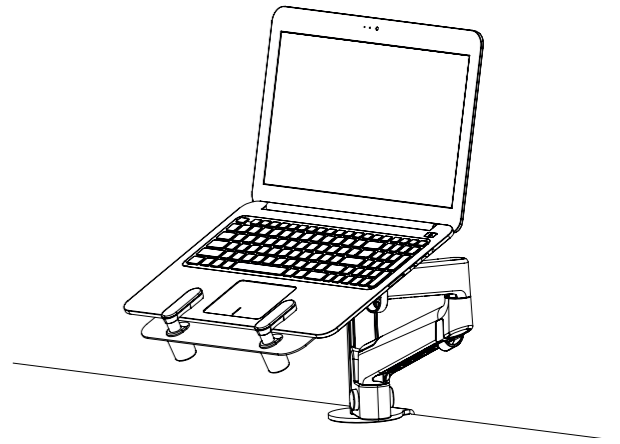

**LIMA LAPTOP MOUNT
INSTALLATION INSTRUCTIONS**

LAP/004

