



# TECHNICAL SPECIFICATION SHEET

**PRODUCT NAME:** Tabetha

**PRODUCT CODE:** TAB/001/W

Doc Rev 1

Product Rev:1

01.02.2017 CF.

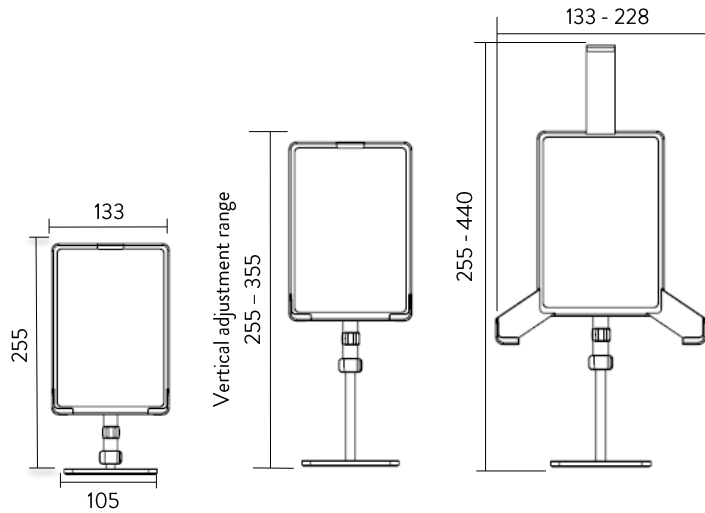

Min/max tablet dimensions

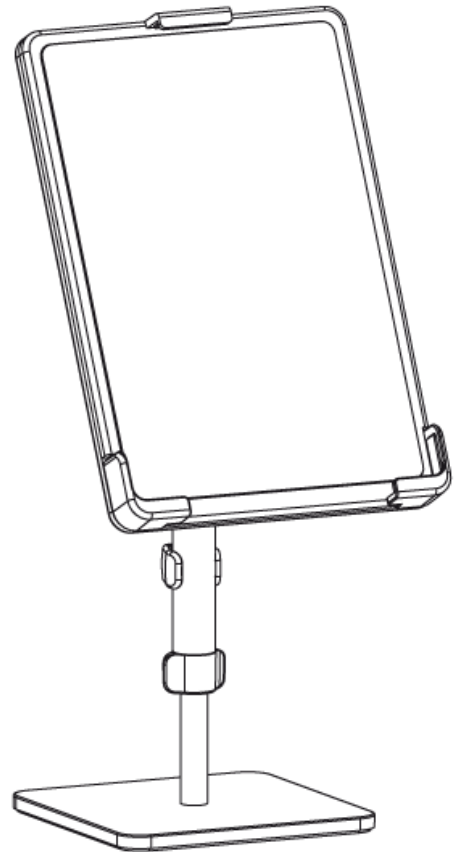
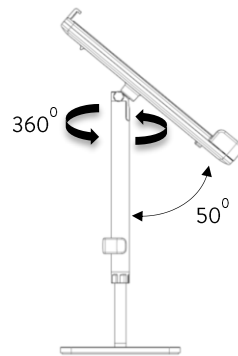
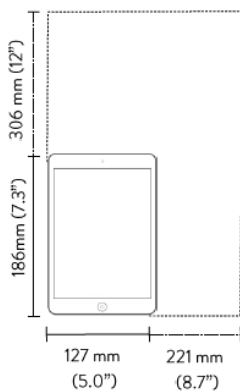

\*Note that dimensions provided are measured in mm

## KEY FEATURES

- Portrait/landscape tablet mounting, tilt adjustment and vertical height range
- Three arms are designed to be manually adjusted to fit tablet sizes from 7" to 12.9"
- Two slide buttons in the back secure tablet in place and allow quick release
- Soft pads on mount surface and arms protect tablet from scratches.

<b>Product Classification</b>	Accessories
<b>Max Load</b>	0.8 kg (1.8 lbs)
<b>Tilt Range</b>	From vertical to 50°
<b>Vertical Range</b>	100 mm
<b>Total recycled content</b>	9%
<b>Total product recyclable</b>	100%

## LOGISTICAL

---

Box contains	Tablet holder incl. base, cable management clip, instructions
Product net weight	0.86 kg
Box dims (HxWxD)	267 x 150 x 115 mm
Box gross weight	1.02kg
Carton quantity	6
Master dims (HxWxD)	452 x 282 x 183 mm
Master weight	6.7 kg
Country of origin	China

## ORDERING INFORMATION

---

<u>Product Description</u>	<u>Product code</u>	<u>Colour</u>
Tablet Mount	TAB/001	:/W White

## WARRANTY

---

Warranty Term	5 years
---------------	---------

## COMPLIANCE & SAFETY CERTIFICATION

---

Whilst no mandatory standards apply to the tablet mount product sector, Colebrook Bosson Saunders Tabetha has been designed to confirm the requirements of BS EN ISO 12100-2:2008 Safety of Machinery – Basic Concepts, general principles for design.

Conformance certification	N/A
Test authority	CBS
Safety certification	N/A

## ENVIRONMENTAL

Material Make-up			Total Recycled Content	Breakdown of Recycled Content		Total Recyclable	
Overall Product			Overall Product			Overall Product	
Material type	Total Material type weight (g)	Percentage of Total Product Weight (%)	Material-Type Recycled Content (%)	Percentage PIR of total weight (%)	Percentage PCR of total weight (%)	Total Product Recyclable (g)	Total Product Recyclable (%)
Steel	594	69%	9%	2%	7%	594	69%
Plastic	222	26%	0%	0%	0%	222	26%
Rubber	44	5%	0%	0%	0%	44	5%
<b>Total</b>	<b>860</b>	<b>100%</b>	<b>9%</b>	<b>2%</b>	<b>7%</b>	<b>860</b>	<b>100%</b>

PIR = Post Industrial Recycled  
PCR = Post Consumer Recycled

Total Product Weight (%)

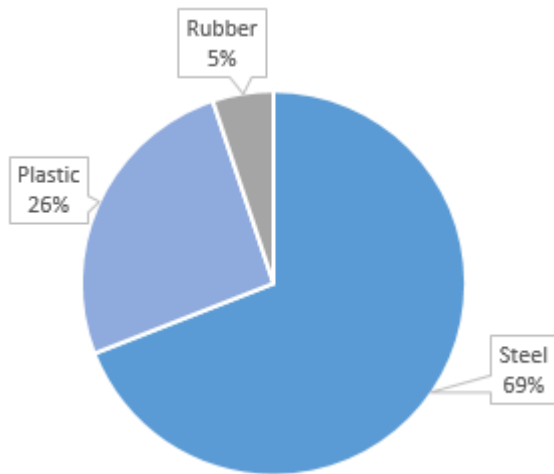

Total Product Recycled Content (%)

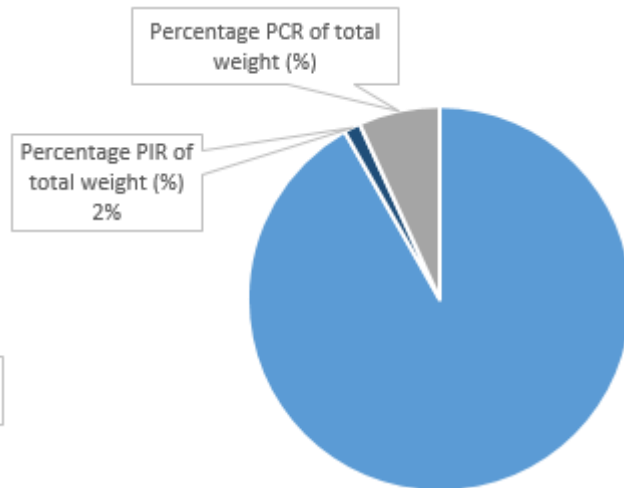

## CLEANING, STORAGE & MAINTENANCE

### Routine servicing

Periodic inspection

### Service components

Available to order

### Cleaning & Maintenance

Damp cloth, no abrasives, no solvents to be used on the cosmetic surfaces

### Handling & Storage

Do not drop or expose to moisture

Whilst every effort is made to ensure the accuracy of our technical information, Colebrook Bosson Saunders (Products) Ltd accept no liability for the accuracy of the information contained in this document and retain the right to modify the data presented herein without prior notification.